



AFWERX  
AFVENTURES

**AFX24.5 & AFX24.D Open Topic  
Phase I Overview & AMA**

**29 February 2024**

# Rules of Engagement

1. Call is recorded
2. No Classified/Proprietary Information
3. Post Questions in Q&A portion

**All information is subject to change.  
The final, authoritative source of info & requirements  
is the solicitation instructions found on DSIP.**

# Branch Org Inboxes

- Open Topic Phase I: [p1@afwerx.af.mil](mailto:p1@afwerx.af.mil)
- Open Topic Phase II: [p2@afwerx.af.mil](mailto:p2@afwerx.af.mil)
- Specific Topic: [usaf.team@afsbirsttr.us](mailto:usaf.team@afsbirsttr.us)
- STRATFI/TACFI: [stratfi.tacfi@afwerx.af.mil](mailto:stratfi.tacfi@afwerx.af.mil)



Visit our website at [AFWERX.com](https://afwerx.com)  
and social media channels:



# DAF Open Topic Solicitations

Topics are truly “open” and agnostic of industry, technology, or problem area.

**We are seeking...**

- Innovative, dual-use tech solutions (i.e. applicable to defense and non-defense)
- Clear potential to solve a DAF mission need (USAF, USSF, or both)
- Capability to prototype under an accelerated schedule
- Ability to scale and grow the industrial base for defense
- Applied R&D efforts rather than “front-end” or basic research

# Open Topic Annual Cycle

## ANNUAL CYCLE FOR DAF SBIR/STTR OPEN TOPIC

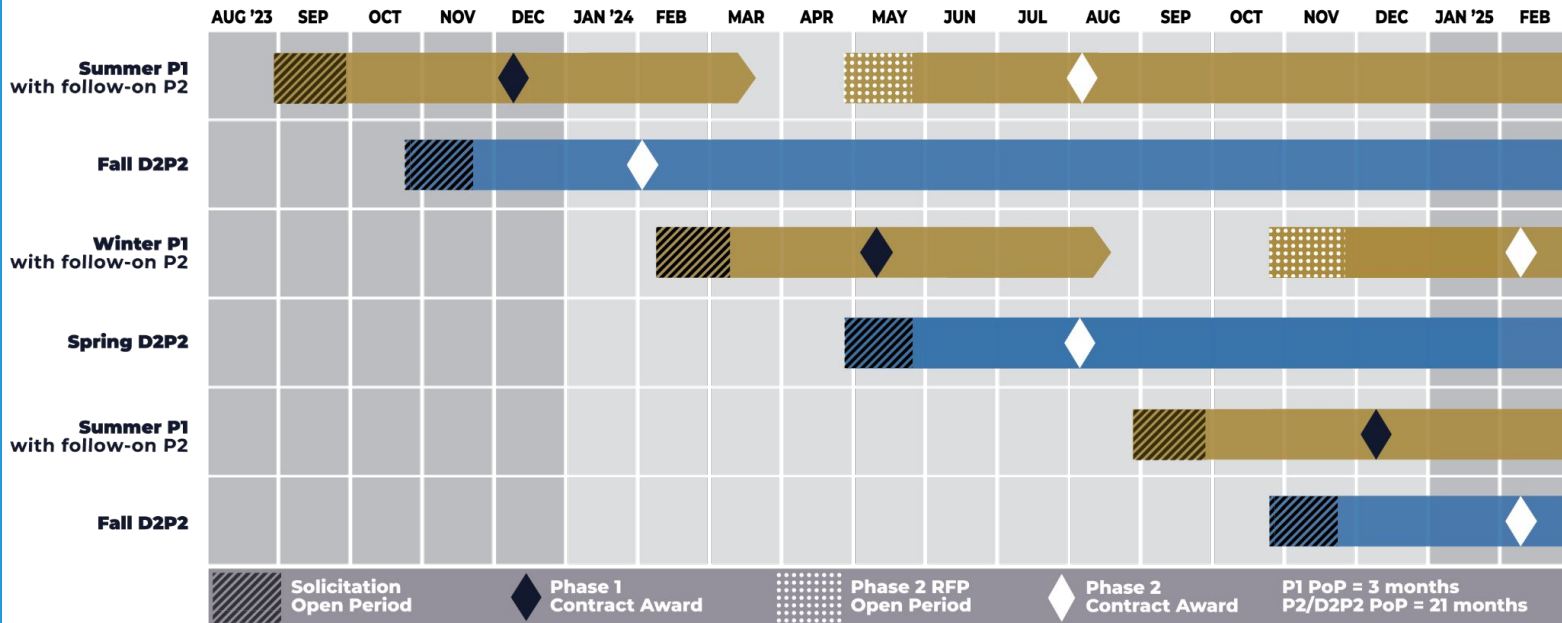

**NOTE: Dates are subject to change.**

## Open Topic Limits

### Phase I Feasibility Study

- Up to \$75K per award (SBIR)
- Up to \$110K per award (STTR)
- 3 month period of performance
- ~700 awards per year

### Phase II Prototyping

- Up to \$1.25M per award (SBIR)
- Up to \$1.8M per award (STTR)
- Up to 21 month period of performance
- ~350 awards per year

**Phase I releases include SBIR and STTR.**

**D2P2 releases are SBIR only.**

# Solicitations vs. Topics\*

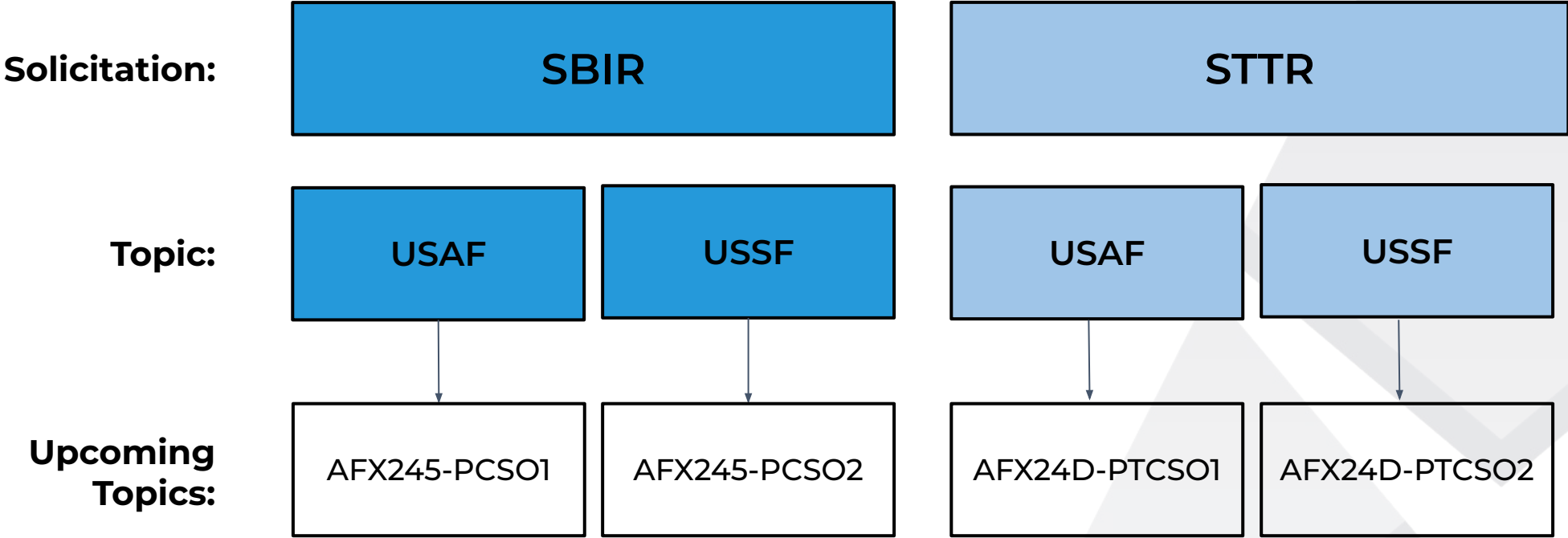

\*Only applies to Open Topic. Specific Topic uses a different framework.

# Evaluation Rules

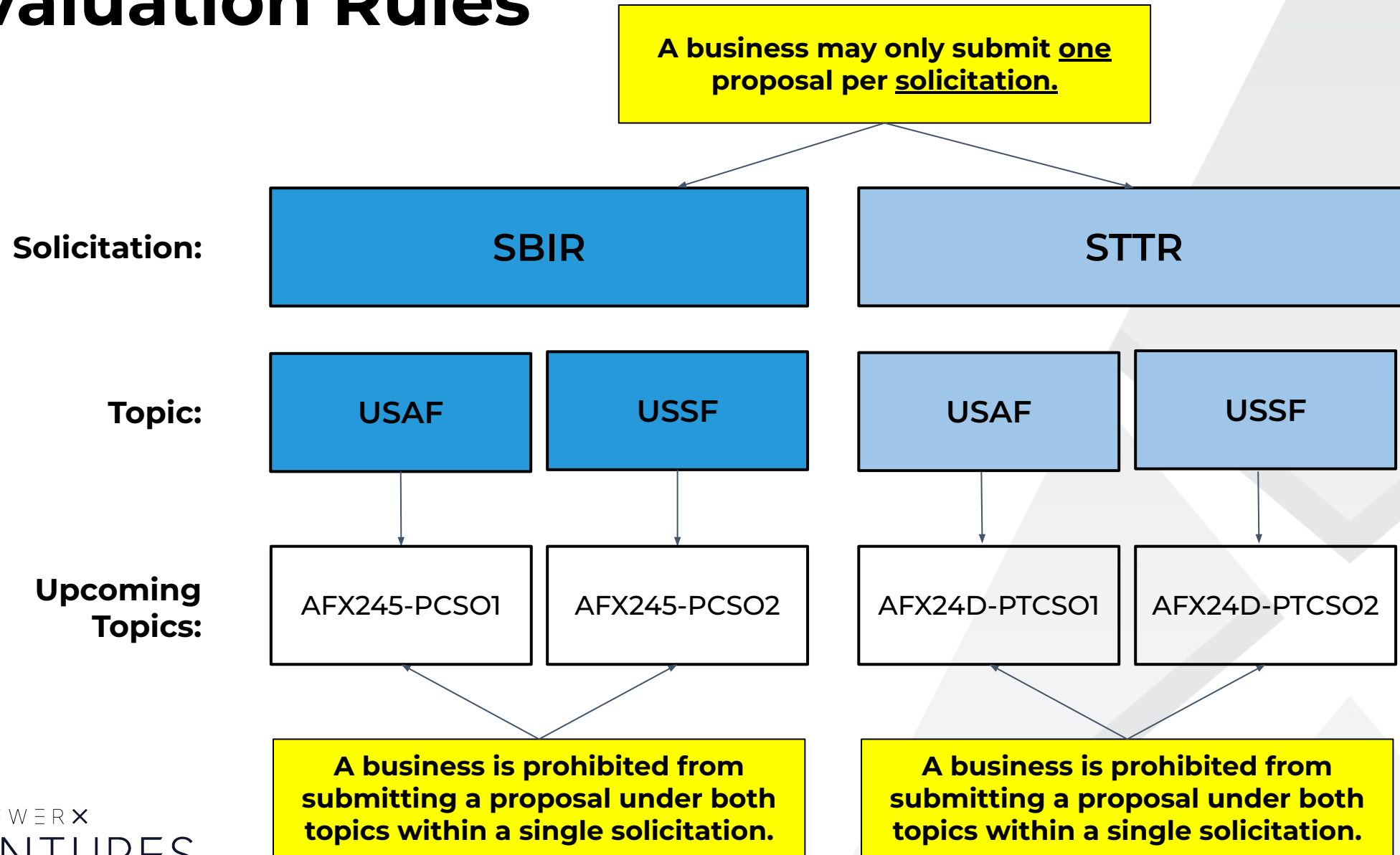

# Solicitation Highlights

## Open Topic Phase I SBIR/STTR

- Purpose: Find the fit between your validated non-defense commercial product and the defense market
- Period of Performance (PoP): up to 90 days
- Funding Limits: up to \$75K (SBIR) and \$110K (STTR)



# SBIR vs STTR Requirements

## STTR is Similar to SBIR

- Three phase commercialization program codified in statute
  - Discover (P1) – Prototype (P2) – Transition (P3)
- Results in sole-source justification for use by \*all US federal agencies\*

**BUT,**

## STTR has unique qualities based on its research focus

- Requires **one** qualifying research institute to perform **30% - 60%** of work (e.g. university, non-profit, or Federally Funded Research & Development Center (FFRDC))
- Principal Investigator (PI) may be primarily employed by research entity (e.g. professor) or the small business
- Leverages close ties with both Federal R&D and operational communities

# What is Research or Research & Development (R/RD)?

SBIR/STTR programs are funded by Research, Development, Test & Evaluation (RDT&E) Appropriations. Use of these funds is governed by federal financial law. Therefore, proposed projects must meet certain definitions and requirements to be eligible for SBIR/STTR funding.

## Research or Research & Development (R/R&D):

- A **systematic study** directed specifically toward **applying knowledge and innovation to meet a recognized but unmet need**
- A **systematic application of knowledge and innovation** toward the production of useful materials, devices, and systems or methods, **including design, development, and improvement of prototypes and new processes** to meet specific requirements.

## Suggestions:

- Ensure your proposal explicitly explains the RDT&E work you will be accomplishing
- Ensure the proposal does not lump R&D costs under licensing to provide clarity to actual costs

# R/R&D concerning COTS & NDIs

Items purchased directly from a commercial source that can be utilized without alteration through design and development, or without modification, are Commercial Off-the-Shelf (COTS) or Non-Developmental Items (NDI). This includes ready-to-use software, training services, and ready-to-use products.

COTS and NDIs by themselves are not suitable for SBIR/STTR funding.

**\*\*HOWEVER\*\***

There **may** be exceptions if:

- The end item requires design and development in order to accept the COTS/NDI
- The COTS/NDI are required for RDT&E test purposes
- The proposal involves significant modification of COTS/NDI
  - To satisfy user requirements
  - Develop a capability

# SBIR/STTR Proposal Structure

- **Vol 1: Proposal Cover Sheet (SAM, UEI, CAGE, Abstract, etc)**
- **Vol 2: Technical Volume**
  - Maximum of 25 slides (**11 required**, 6 required as applicable, remaining at applicant's discretion)
- **Vol 3: Cost Volume**
  - System formatted inputs
- **Vol 4: Company Commercialization Report (CCR)**
  - Follow solicitation instructions for Volume 4
  - CCR information is maintained and report is generated via sbir.gov
  - CCR is uploaded to DSIP as part of the proposal submission process, as applicable
- **Vol 5: Supporting Documents**
  - Additional Cost Info (your preferred format)
  - **\*IP Agreement with RI (SBA template available) (STTR ONLY)**
  - Resumes for key personnel
  - DoD Funding Agreement Certification
  - Work Plan (Non-proprietary)
  - Additional Required Attachments (Ie: Lifecycle Certification, ESOH Questionnaire)
  - **Attachment 4: Disclosures of Foreign Affiliations or Relationships to Foreign Countries**
- **Vol 6: Fraud, Waste, and Abuse Training**

**IMPORTANT NOTE:**  
Proposals that do not include Attachment 4  
will be deemed noncompliant and will not  
receive an evaluation.

# Submission Requirements

- All eligible offerors must be qualifying, registered small businesses in SAM.gov
- Complete proposals must be submitted via the Defense SBIR/STTR Innovation Portal (DSIP)
  - We cannot pre-read or recommend proposals or receive non-DSIP submissions
- **Must be Research, Development, Test, and Evaluation (RDT&E) activities**
  - Not services, not procurement
  - See modified-COTS description in solicitation
- **Fraud, Waste, and Abuse training - completed by applicant**
  - Must be completed by one DSIP firm user with read/write access (Proposal Owner, Corporate Official, or Firm Admin) on behalf of the firm.
- **STTR ONLY - Must propose effort with a qualifying RI subcontractor**
  - $\geq 40\%$  to the Small Business
  - $\geq 30\%$  to one Research Institution (RI)
  - 30% trade space (Small Business, RI, subcontractor, secondary RI, etc)
- **Proposals not meeting the above will not be considered**

# Common Causes for Non-selection

- Exceeding Cost or Duration Limits - \$75K (SBIR) and \$110K (STTR); 3 months max
- SAM.gov Registration - firms must have an active registration
- Missing Documentation - be sure to include all required Volumes and attachments
- Multiple Submissions
  - A small business concern may only submit one proposal under each solicitation.
  - A small business concern is prohibited from submitting a proposal under both topics (i.e., submit to both the AF and SF topics of a single SBIR solicitation).
  - If more than one proposal from a small business concern is received for a single solicitation, **only the most recent proposal to be certified and submitted prior to the submission deadline** will receive an evaluation.
- Not clearly addressing evaluation criteria (see section 6)

# What's Next?

- **Proposals due Thursday, March 7th @ Noon Eastern**
  - Do not wait until the end of the submission period to submit proposal materials
  - All proposals must be submitted via DSIP (<https://www.dodsbirsttr.mil/>)
- **Be familiar with Evaluation Criteria (Solicitation Section 6)**
  - Commercialization Potential
  - Defense Need
  - Technical Merit
- **Questions must be answered via DSIP Q&A or AMA webinars**
  - The solicitation instructions provide your best source of information

# Solicitation Resources

Contracting Officer: Mr. Daniel Brewer

Program Manager: Ms. Emily Primeaux

For questions, utilize DSIP Q&A section

<https://www.dodsbirsttr.mil/submissions/baa-schedule/active-baa-announcements>

Additional resources can be found at [AFWERX.com](https://www.afwerx.com)





ΛFWERX  
ΛFVENTURES

**Questions?**

Please type your questions in the Q&A section.



# AFWERX AFVENTURES

## Still have questions?

**Specific Topic:** [usaf.team@afsbirsttr.us](mailto:usaf.team@afsbirsttr.us)

**Open Topic Phase I:** [p1@afwerx.af.mil](mailto:p1@afwerx.af.mil)

**Open Topic Phase II:** [p2@afwerx.af.mil](mailto:p2@afwerx.af.mil)

**STRATFI/TACFI:** [stratfi.tacfi@afwerx.af.mil](mailto:stratfi.tacfi@afwerx.af.mil)



Let us know how we are doing. Please complete the survey as you leave today's meeting.